

# AMERICAN RANGE

Chef Inspired, Professional Cooking Equipment

## Culinary Series AF-75 HEAVY DUTY FRYER

### STANDARD FEATURES

- Stainless steel heavy duty construction.
- Extra depth oil level for frying larger products.
- Front slanting vessel bottom for quick and easy draining.
- Ample “cool zone” prevents trapped food particle carbonization while extending oil life.
- Highest **Power-Plus** BTUs for instant recovery at during extreme peak periods. 4 Burners, **Power-Plus** 40,000 BTU each/**Power-Plus** 160,000 BTU total
- Rugged double layer access door.
- Thermostatic control from 200°F - 400°F.
- Millivolt System with 100% safety shut off.
- No electrical power required.
- 304 stainless steel precision TIG welded tank for long life.
- Removable hanger accommodates two fry baskets.
- 3/4” NTP gas inlet in rear of unit.
- High-Limit Safety Switch Standard
- Two year limited warranty, parts and labor.

### OPTIONAL FEATURES

- Stainless steel tank cover.
- Casters (2 locking).
- Matching “Dump Station”.
- Stainless steel splash guard (removable & tool-less).
- Heat lamp for model #ARFDS, stainless steel work top/side tray.
- Stainless steel side tray with pan & cut out.
- Stainless steel Spreader work top solid surface. 12”, 18” & 24”.
- Quick disconnect and flexible gas hose.



GAS TYPE:  NATURAL  LP



**Model Shown AF-75**  
Comes with optional casters

**Power-Plus**  
4 each 40,000 BTU/hr. Burners  
(160,000 total BTU's)

The **Culinary Series** by American Range, with the latest technology incorporated into its design, and tons of features and benefits to suit the everyday demanding needs especially during extreme operating periods. Bringing added value and assured performance, by offering the highest **Power-Plus** BTU rating for superior recovery. The ample cool zone prevents food particles from carbonization while extending oil life. Our unique vessel tank design features a deeper oil level, for larger food products, and a sloping vessel bottom for quick and complete draining of oil and debris.

Its special design tube shields provide a uniform heating pattern for positive, more consistent frying results. Equipped with a Millivolt Control System, and a 100% safety shut off valve. No electrical power is required. Conveniently located controls for easy access for operators, maintenance and service. All stainless steel heavy duty exterior. Durable, double panel door, rugged base and removable stainless steel basket guide. Equipped with two nickel plated baskets with cool grip plastic coated handles provide maximum operator comfort.

Quality, dependability and customer satisfaction make American Range the **brand of choice among professional chefs and restaurateurs worldwide.**

# Culinary Series

## AF-75 HEAVY DUTY FRYER

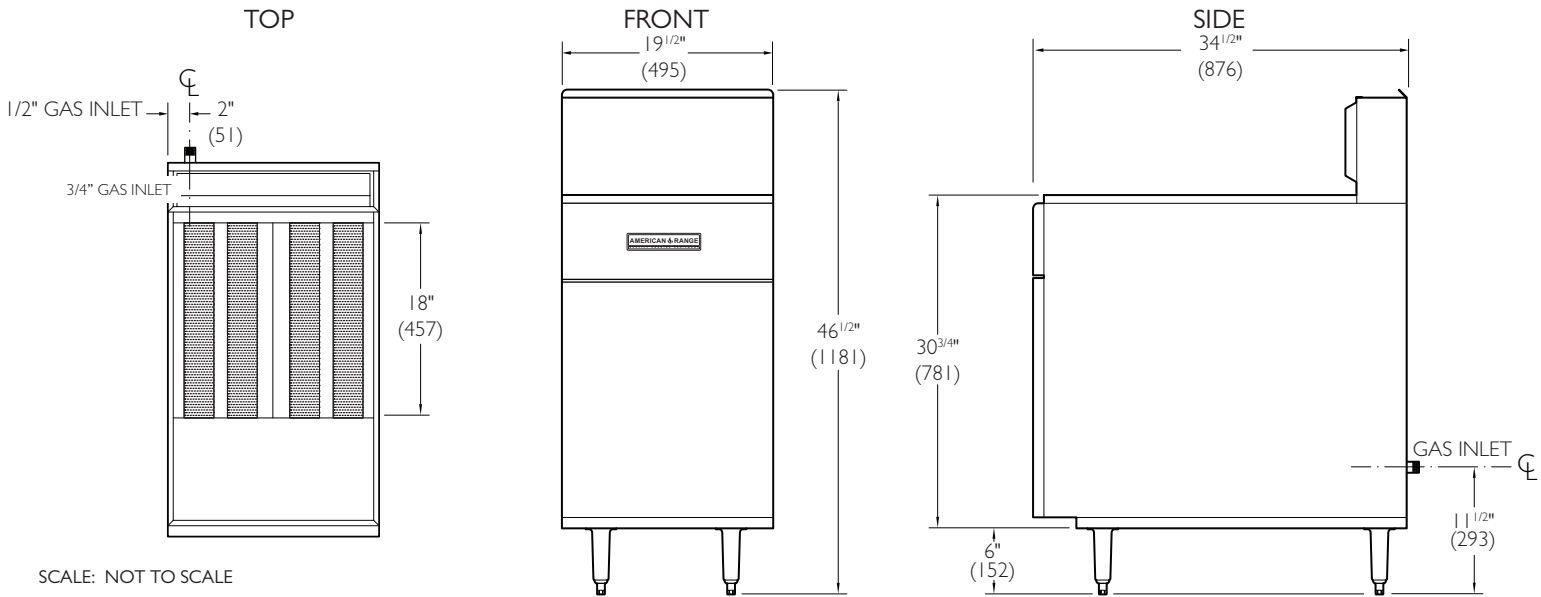

SCALE: NOT TO SCALE

### AF-75 HEAVY DUTY RESTAURANT FRYER

Model	Total BTU	KW	Width	Depth	Height	Cooking Area	No. of Burners	Shipping Weight Lbs. (Kg.)
AF-75				One Pot				
65lbs. - 80lbs.	160,000	(47)	19 1/2" (495)	34 1/4" (870)	45 3/4" (1162)	18" x 18" (457 x 457)	4	198 (90)

#### FEATURES

- 80 Lb. tank oil capacity
- Fryer vessel tank: All stainless steel high quality construction, 16 gal. #304 material
- Exterior: All stainless steel front, sides, door and basket hanger/flue riser.
- Stainless steel: Door: Durable double layer access door
- Basket Hanger: Removable basket hanger accommodates a large fryer basket.
- Fryer Baskets: Nickel plated fryer basket with cool grip plastic coated handle for operator safety and ease.
- millivolt control system: No electrical hook up required.
- Thermostatic Control: Thermostat adjusts from 200°F to 400°F.
- Safety shut off System: 100% gas shut off when temperature reaches the hi-limit.
- Combination Gas Valve: Includes pressure regulator and pilot ignition system, hermetically sealed for operating stability. 3/4" NPT gas inlet in rear.
- Crumb Screen: Large removable tight mesh nickel plated screen under fryer basket.
- Drain Valve: 1" (38) diameter opening for easy draining of oil.
- Plastic coated handle for safety.
- Legs: 6" (157) high chrome plated adjustable legs.
- 4 Burners, **Power-Plus** 40,000 btu each/**Power-Plus** 160,000 btu total

#### OPTIONAL FEATURES

- Casters: 6" (152) high casters front two with locking brakes.
- Tank Cover: Stainless steel cover to fit over fryer tank.
- Joiner Strip: Connects two fryers and prevents oil from getting in between the fryers or drain station.
- Quick Disconnect: Gas hose with restraining device for added safety.
- Dump Station: Stainless steel dump station with door and convenient cabinet below.
- Stainless steel side tray for working surface or dump station, can be used with optional heat lamp.
- Stainless steel Splash Guard (removable and tool-less).

#### GAS SUPPLY:

3/4" NPT Gas inlet. Manifold pressure is 5.0" W.C. for natural gas or 10.0" W.C. for propane gas. Specify type of gas and altitude if over 2000 feet.

#### CLEARANCES:

For use only on non-combustible floors. Legs or casters are required, or 2" (51) overhang is required when curb mounted. Clearance from non-combustible walls is 0". When unit is placed next to combustible walls, clearances must exceed 12" (305) on sides, and 4" (102) from rear. Radiant broilers for non-combustible locations only.

American Range is a quality manufacturer of commercial cooking equipment. Because of continuing product improvements these specifications are subject to change without prior notice.



A70160  
05042021



13592 Desmond St. Pacoima CA 91331  
T. 818.897.0808 F. 818.897.1670  
Toll Free: 888.753.9898  
www.americanrange.com